



RCA MANUFACTURING COMPANY, INC.

A RADIO CORPORATION OF AMERICA SUBSIDIARY

Harrison, New Jersey

RCA RADIOTRON
D I V I S I O N

APPLICATION NOTE No.102

March 15, 1939

APPLICATION NOTE
ON
THE 6SK7 AS AN I-F AMPLIFIER

An important advantage of the 6SK7 is its high transconductance. When the design of an i-f stage is changed to use the 6SK7 in place of the 6K7, the increase in transconductance enables the designer to increase gain, or it enables him to improve selectivity, or it may enable him to reduce i-f transformer cost. It is the purpose of this Note to show how these improvements can be made.

Increase of Gain

When it is desired to obtain an increase in gain from the change in tubes, it is important that wiring be arranged so as to cause as little feedback as possible. It has been found good practice, in i-f stages using the 6SK7, to locate the avc filter resistor close to the diode load resistor. The reason is illustrated by Fig.1 which shows a widely used avc circuit. In this circuit, if the avc filter resistor R were close to condenser C, there would be considerable i-f voltage between lead XY and ground. Because this lead, and the lead to the 6SK7 grid, are both under the chassis, the large i-f voltage on lead XY might cause objectionable feedback to the 6SK7 grid. This feedback is greatly reduced when resistor R is placed close to the diode load, as in Fig.1, because this placement reduces the i-f voltage on lead XY. Also, it has been found good practice to place the 6SK7 screen by-pass condenser across the 6SK7 socket so that the condenser will shield the grid terminal from the plate terminal. In some cases, it is advisable to place "hot" i-f leads close to the chassis so as to utilize the shielding effect of the chassis. By means of these and similar precautions against feedback, it is possible to change many 6K7 i-f stages over to use the 6SK7 without the necessity for alteration of i-f transformer design. When the change in tubes is made in this way, the gain of the stage is increased in proportion to the increase in transconductance. For a stage operated at 250 volts plate voltage and 100 volts screen voltage, the increase in gain is 38%.

Alteration of I-F Transformer

In some i-f stages, however, the change to the 6SK7 causes instability in spite of well-arranged wiring. The reason is that feedback through

Copyright, 1939 by
RCA Manufacturing Co., Inc.

AN-102-2-28-39
Printed in U.S.A.



grid-plate capacitance reflects into the grid circuit a negative resistance which is proportional to the product of the resonant impedance of the plate load, the transconductance of the tube, and the capacitance between grid and plate. The stability of the stage depends on the sum of this negative resistance and the positive resistance due to losses in the grid circuit. The change to the 6SK7 increases the reflected negative resistance because the transconductance of the 6SK7 is higher than that of the 6K7, while the grid-plate capacitances of the two tubes are equal. The change to the 6SK7 may, therefore, cause instability in a stage where the resonant impedance of the plate load is high. A convenient way to eliminate this instability is to alter the output transformer of the i-f stage so as to reduce the plate-load impedance.

In a transformer where the primary and secondary can have different numbers of turns, the reduction of load impedance can be so made that the change in tubes gives an increase in gain with no decrease in stability. When both tubes are operated at 250 volts plate voltage and 100 volts screen voltage, the increase in gain which can be obtained in this way is 17%. However, i-f transformers in receivers are generally required to have primary and secondary coils of equal numbers of turns because this equality simplifies coil winding. When an i-f stage using such a transformer is to be changed over from the 6K7 to the 6SK7, and the stability of the stage is to be held constant by a reduction of load impedance, the reduction of load impedance must be large enough to hold gain constant. Hence, in such cases, the change from the 6K7 to the 6SK7 will not yield any increase in gain. The change, however, can be made to yield other improvements. The nature of these improvements depends on the method by which plate-load impedance is reduced. There are three different methods which give different results.

Single-Circuit Analogy

The discussion of these methods can be simplified by considering first the single tuned circuit shown in Fig.2, where R represents the series resistance of the coil. As is well known, the resonant impedance of this circuit, when the coil Q is reasonably high, is L/RC , and the selectivity of the circuit is determined by the coil Q. It can be seen that one way to reduce the resonant impedance of the circuit is to reduce the ratio of L/C , with the ratio of L/R held constant. The reduction of L/C is, of course, to be so made as to leave the resonant frequency unchanged. This method of reducing impedance does not affect the coil Q, and, therefore, does not affect the circuit's selectivity. However, when the circuit is used as plate load in an amplifier, this method of reducing impedance increases the selectivity of the amplifier. The reason is that this method increases the conductance of the tuned circuit and, therefore, reduces the shunting effect on the circuit of the driving tube's output conductance and the following tube's input conductance. For example, let the conductance of the coil be g_c and the sum of the tube conductances be g_t . The total conductance is $g_c + g_t$, and the ratio of susceptance to total conductance, the Q of the circuit as a whole, is to a good approximation

$$1$$

$$\frac{1}{\omega L(g_c + g_t)}$$

It is this Q which determines the selectivity of the amplifier. If the inductance of the coil is multiplied by a factor $1/A$, with coil Q held constant, the Q of the circuit as a whole becomes

$$\frac{A}{\omega L(A g_c + g_t)}$$

If A is greater than 1, this Q is larger than the former Q . It follows that selectivity is increased when L/C is reduced with coil Q and resonant frequency held constant.

A second method of reducing impedance is to decrease both L/C and L/R . As has been shown, the reduction of L/C tends to increase the selectivity of an amplifier stage using the circuit, while the reduction of L/R reduces Q and, therefore, tends to decrease selectivity. It follows that a reduction of both L/C and L/R can be so made as to leave selectivity unchanged. Because the cost of a coil usually depends to a large extent on the Q of the coil, this second method may be used to reduce circuit cost without affecting selectivity.

Improvement of Selectivity Curve

This discussion of a simple tuned circuit indicates how load impedance can be reduced when the load is a conventional double-tuned i-f transformer. The curves of Fig.3 show the results obtained when load impedance is reduced by a decrease in the L/C ratio, with coil Q held constant. Curve I shows the selectivity of a typical i-f transformer coupling a 6K7 to a diode. The primary and secondary both have a coil Q of 120, coupling is critical, and gain at resonance is 200. Curve II shows the selectivity obtained when the 6K7 is replaced with a 6SK7, the L/C ratio is reduced sufficiently to maintain gain at 200, the Q of the coils is held constant, and coupling is again critical. It can be seen that the response of the 6SK7 at 10 kc off resonance is down to 18% of maximum, as compared with 28% for the 6K7. The reason for this improved selectivity is the same as that mentioned in connection with the single tuned circuit. The reduction of the L/C ratio increases the conductance of the primary and secondary and, therefore, decreases the shunting effect on the transformer of the diode circuit and of the i-f tube's output conductance. The result is that, even though coil Q has not been changed, the Q of the circuit as a whole has been raised and, therefore, selectivity has been increased.

In some receivers, the side-band response of Curve II may be less than is desired. Side-band response can be improved by an increase in the coupling of the transformer, as illustrated by Fig.4. In this figure, Curve I is for the 6K7 stage which has been described. Curve III shows the selectivity obtained when the 6K7 is replaced with a 6SK7, the Q of the coils is held constant, the L/C ratio is reduced, and the coupling is increased sufficiently to give the same gain at resonance and at 10 kc off resonance as shown in Curve I. Curve III shows that the change from a 6K7 to a 6SK7 can be made to provide better side-band response, with no change in gain or in coil Q , and with no increase in interference from stations on adjacent channels. The negative resistance reflected

into the grid circuit in the stage represented by Curve III is practically the same as that of the stage represented by Curve I; the two stages, therefore, have the same stability.

Reduction of Coil Cost

The second method of reducing the impedance of a single tuned circuit, the method in which both L/C and coil Q are reduced so as to maintain selectivity unchanged, can also be applied to a double-tuned i-f transformer. For example, computations show that Curve I, which is for a 6K7 and a critically coupled transformer having a coil Q of 120, can be provided by a 6SK7 and a critically coupled transformer having a coil Q of 94. In other words, the stage represented by Curve I can be changed over to use the 6SK7 with a 20% reduction in coil Q and no change in gain or selectivity. This reduction in coil Q may make it possible to reduce the cost of the transformer.

Computation of Curves

Curve I

Curve I is computed for a 6K7 i-f stage driving a diode detector. Both the primary and secondary coils of the i-f output transformer have an inductance of 1.62 millihenry and a Q of 120. The total capacitance across each coil is 75.5 μf . The primary is shunted by conductances of 1.25 micromhos due to the plate resistance of the 6K7, and 0.3 micromho due to losses in the 6K7 base and socket. The secondary is shunted by conductances of 1.8 micromhos due to a diode load of 1 megohm and a rectification factor of 90%, and 0.3 micromho due to losses in the diode base and socket. Coupling is critical. Plate voltage is 250 volts, screen voltage is 100 volts, and grid bias is -3 volts. The transconductances of the 6K7 is 1450 micromhos and gain at resonance is 200.

Curve II

Curve II is computed for the i-f stage of Curve I after the 6K7 has been replaced with a 6SK7 and the primary and secondary have been changed to 0.918 millihenry and 133 μf so as to hold gain at 200. Coil Q, the loading conductances, and electrode voltages are the same as for Curve I, and coupling is critical. The transconductance of the 6SK7 is 2000 micromhos.

Curve III

Curve III is computed for a 6SK7 and an overcoupled output transformer giving the same gain at resonance, and at 10 kc off resonance, as the stage represented by Curve I. Primary and secondary inductances are 1.00 millihenry, capacitances are 122 μf , and coupling is 1.37 times the critical value. Coil Q, electrode voltages, and the loading conductances are the same as for Curve I.

Transformer giving response of Curve I with 6SK7

The critically coupled output transformer giving the response of Curve I with a 6SK7 has a primary and a secondary inductance of 1.17 millihenries, a primary and a secondary capacitance of 104 μf , and a coil Q of 94. This coil Q is 20% less than the coil Q of the transformer with which Curve I was obtained using a 6K7. The loading conductances and electrode voltages used in computing the transformer for the 6SK7 are the same as those specified for Curve I.

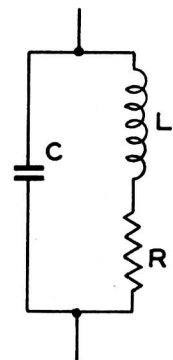
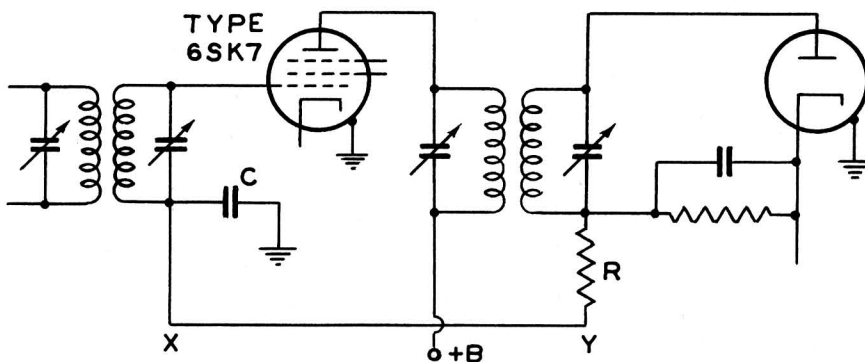

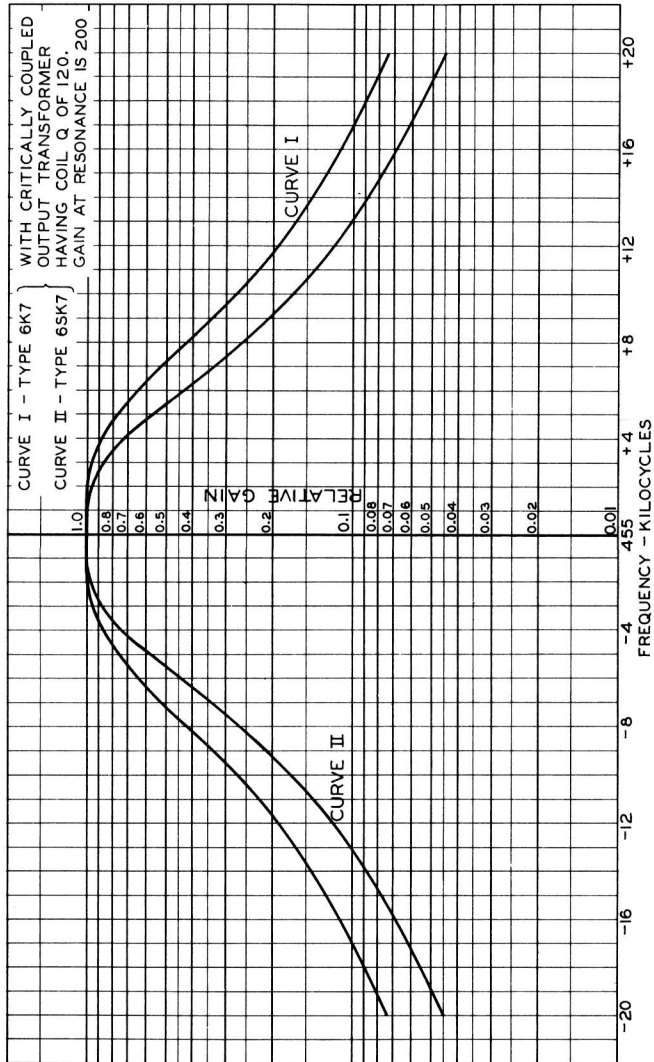

FIG. 3

FEB. 20, 1939

RCA RADIOTRON DIVISION
RCA MANUFACTURING COMPANY, INC.

92C-6028

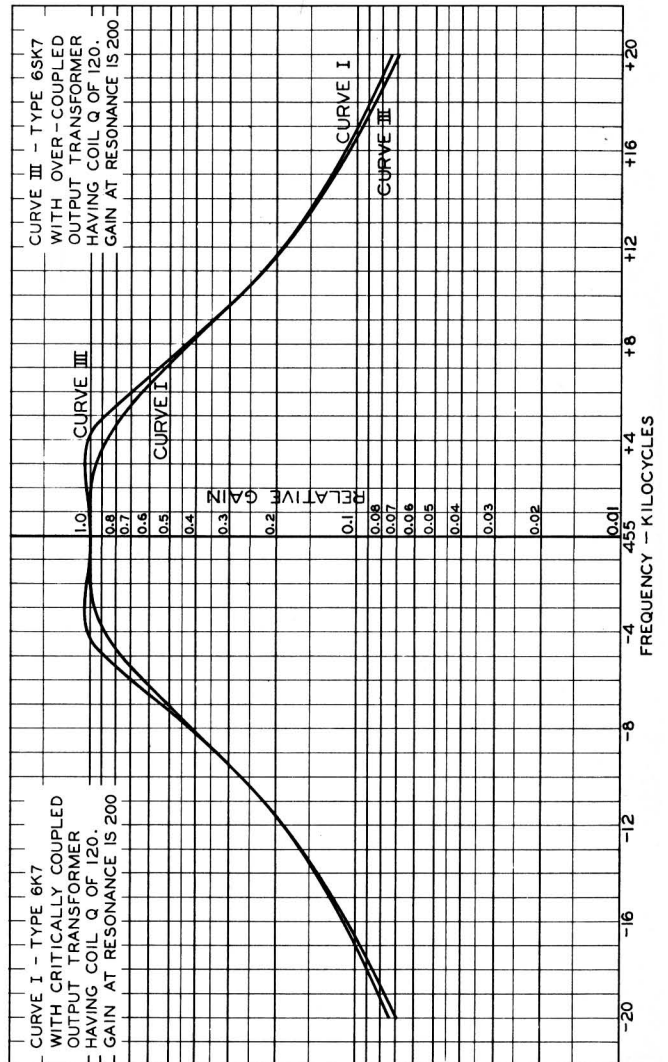

FIG. 4

FEB. 20, 1939

RCA RADIOTRON DIVISION
RCA MANUFACTURING COMPANY, INC.

92C-6029